

# Kitchen Maker

Issue 47

Online

**LET THE SUNSHINE  
INTO YOUR KITCHEN**

Premium class  
sliding table saws.

# T66

## T66 with ConnectControl

With the new MARTIN T66, we have developed a real all-rounder that combines the advantages of the large machines. The machine with a saw blade that can be tilted to one side is the ideal entry into the MARTIN world of sawing and convinces with practical advantages for your everyday work. For example, the T66 offers powerful, continuously adjustable rotational speed control already as standard.

ConnectControl stands for the patented control concept that characterises the latest generation of sliding table saws from MARTIN. With ConnectControl, you get a uniquely designed, highly efficient control concept that not only opens up completely new horizons for machine operation, but also unlocks the entire world of modern data exchange.



# MARTIN

www.martin.info

### England and Wales

MWM Markfield Woodworking Machinery Ltd. – www.mwmachinery.co.uk

### Scotland

AWMS Engineering Ltd. – www.awmsltd.co.uk  
WS Woodmachinery – www.wswoodmachinery.co.uk

### Northern Ireland

Electro Tech Machinery Ltd. – www.electrotechmachinery.com

### Republic of Ireland

HIGH-TECH MACHINERY Ltd. – www.high-tech.ie



# LET THE SUNSHINE INTO YOUR KITCHEN

KITCHEN COLOURS

IT is true we all feel better as soon as the sun begins to shine, but here in the UK sunshine can sometimes seem like a rare (and precious) commodity.

At least throughout the months of July and August, we have the chance to get out and about, maybe enjoying a picnic on the beach, or at a favourite spot in the countryside, but what can we do during those long winter months, when we need the pick-me-up of a bright, sunny environment and we look outside our kitchen window and everything we see is 50 shades of grey?

Surely, one simple answer is to bring the sunshine in.

When it comes to the use of bold colours, the kitchen is the one place in a home you do not have to play it safe. Cooking spaces can convey a sense of happiness thanks to the addition of a brilliant shade of buttercup yellow, warm shades of maple gold, or a splash of acidic lemon.

If your kitchen feels starved of natural light, or could use a few splashes of room-warming color, yellow will invigorate your space with a sunshiny vibe.

Don't imagine that you have to paint everything to match the colour of the slice of lemon in a gin and tonic. Yellow is nothing if not a refreshing shade and comes in a wide range of beautiful hues ranging from amber to muted creams and chartreuse through to saffron — and all these shades will brighten things up whilst evoking that cozy feeling.

In order to provide some inspiration to enable you to liven things up, here are our favorite ideas for creating a yellow kitchen.

One of the freshest décor current trends re-invents the classic yellow-and-brown 1970s kitchen. Combining glossy surfaces with rustic textures in the cooking space can certainly make any kitchen feel up to date.

Bright yellow will always serve to warm up plain crisp, pale walls. Base cabinets painted in this manner will heap on the colour, as well as how happy we feel when preparing the evening meal at the end of a long, hard working day.

Yellow looks terrific against natural, unpolished timbers and even oak veneers. Mustardy colouring can be used to good effect on the wood cabinetry whilst offsetting the stainless steel worktops.

Underfoot try combining square,



VISIT US AT [WWW.KITCHEN-MAKER.CO.UK](http://WWW.KITCHEN-MAKER.CO.UK) - ONLINE MAGAZINE



bright yellow floor tiles with black ones laid down in a chequerboard pattern for a totally stunning look.

Brilliant primary yellow hues can provide an excellent contrast to dark hunter greens. Adding a dash of red will certainly serve up a sense of exuberance.

Cool colours can make an interior that does not receive much natural light feel dark and uninviting, but add cabinetry in punchy sunflower yellow and you will create a totally different look and one in which the dullest of spaces appear to echo the sunlight of a summer's day.

An exuberant shade of yellow will certainly pay dividends in a modern farmhouse kitchen. The optimistic hue adds visual warmth by taking the chill off the stark, plain coloured cabinetry.

It is possible to create the neutral kitchen of your dreams with cabinetry in soft shades of buttermilk. These creamy hue rival white as an enduring classic.

A statement-making appliance can infuse a space with splashy style. Install a range cooker in vibrant yellow and your added emphasis of colour will certainly not go unnoticed. Likewise, a splurge of colour can be provided by the addition of a yellow kitchen island.

Perk up an all-white kitchen with a few vibrant accents. Add flowerpot-shaped pendant lamp in shades of citrus lemon. Bar stools in a vibrant shade of yellow will put you in the hot seat and can easily and cheaply add an accent of much needed colour in an

otherwise plain and lifeless work space.

You can combine old-world charm with modern functionality with the use of primitive-style cabinets in chrome yellow. You can also totally transform a tiny kitchen with an eye-popping splash of sunshine yellow or brighten up an industrial-style white kitchen with bold, yellow features. Bright yellow worktops will have the same effect. Adding a yellow painted splashback is a ridiculously simple way to heat up a kitchen with a splash of yellow.

Muted cream-coloured cabinets and butcher-block countertops can be used to good effect to balance a canary yellow wall.

Simply painting the inside of kitchen cabinets a contrasting shade of yellow will give a definite boost to white cabinetry and reveal an unexpected burst of yellow when the doors are flung open.

Perhaps surprisingly (and one idea which few of us may have considered) is the fact that the combination of bright, buttercup yellow with pillar-box red can work well.

Alternatively, a few pieces of bright yellow furniture can do the same trick, serving to spice up a kitchen in which neutral shades predominate.

Layers of texture, colour and lighting make the kitchen the heart of the house. Indeed there are all manner of different ways in which the colour yellow can be used to bring the sunshine into your kitchen – even on the dullest winter day.



VISIT US AT [WWW.KITCHEN-MAKER.CO.UK](http://WWW.KITCHEN-MAKER.CO.UK) - ONLINE MAGAZINE



# PWS WORKTOP FACTORY CAN NOW BE VIEWED ON FILM

PWS has released a film to promote the many service benefits offered from its state-of-the-art work surface factory.

On of the most advanced production facilities in Europe, the PWS work surface factory combines fully-integrated processes with quality, brand-leading materials and an expert team to deliver what is claimed to be the best product and service in the industry.

The film follows the journey of a typical order, starting with the dedicated sales advisers for a consistent point of contact, through each step of the process, from template, material selection, manufacturing with care and exacting precision, to dispatch and installation.

With a total of nine hubs around the country, PWS offers a local service on a national basis, backed with generous stock-holding of materials to support short lead times.

'Our work surface factory is, without doubt, the most impressive production facility of its type in the UK and our short film re-inforces, in a matter of minutes, the key benefits we can offer customers in terms of service, quality and choice,' says marketing manager, Andrew Langford.

'The film successfully captures the sophistication of the manufacturing machinery and production techniques and the professionalism and expertise of the team behind all aspects of the operation,' adds Andrew Langford, speaking enthusiastically about the film which highlights the various service benefits available from the PWS factory.

PWS offers a wide choice of materials from leading names, such as Corian and Hi-Macs solid surface Silestone and Dekton quartz.

Alongside the extensive range of granite and timber finishes, PWS also promotes Strata – its own brand of quartz and solid worktops.

All PWS work surfaces are quality approved by its major suppliers and come with a 10-year warranty.

The film can be viewed at <https://www.youtube.com/watch?v=Wwgn35kBmLG>.

Want to find out more?  
Visit [www.worksurfaces.pws.co.uk](http://www.worksurfaces.pws.co.uk)



The PWS film follows the journey of a typical order, through each step of the process, from template, material selection, manufacturing with care and exacting precision, to dispatch and installation.

VISIT US AT [WWW.KITCHEN-MAKER.CO.UK](http://WWW.KITCHEN-MAKER.CO.UK) - ONLINE MAGAZINE



WORK SURFACES

Tomba is a new handle-less design from PWS.



Strata is an own brand range of quartz, granite and acrylic work surfaces from PWS, which has recently been boosted with an extensive range of exciting new finishes.

VISIT US AT [WWW.KITCHEN-MAKER.CO.UK](http://WWW.KITCHEN-MAKER.CO.UK) - ONLINE MAGAZINE

# A TOUCH OF GOLD IN YOUR KITCHEN

KITCHEN furniture in gold, or with decorative elements in gold is back in style and we will soon see a lot more of it. In line with this trend, Ostermann offers various matching solutions for the narrow surface of the board.

We have already become used to the sight of gold-coloured accessories in interiors once again. In the future, you will even find the elegant colour again on entire furniture surfaces. Ostermann has the right edgings in store to cover the narrow surfaces.

Among these, ABS edgings with a real aluminium finish are a particularly high-quality solution. They are just as easy to process as standard ABS edgings. A thin layer of real metal gives their surface a realistic look. However, even with ABS material alone, soft gold tones can be created.

Here Ostermann experts present selected solutions that round off golden surfaces, or highlight furniture when used as accentuating edging. All versions presented here are available directly from stock and can be shipped in small quantities from 1m upwards.

## How to blend in pieces of gold

Touche of gold look particularly elegant on anthracite grey, or black plain boards. Whether you combine them with glossy, or extremely matt surfaces does not matter.

What counts is the end customer's personal taste and, of course, the setting in which the furniture is supposed to be placed. A golden edging can also be applied to dark wood decor boards, giving them a stylish finish.

## With Real Aluminium Finish: Alu Oro Cortez

With the ABS edging Alu Oro Cortez exclusive matt brushed, you get an unusual furniture edging, which is not only in line with the "gold" trend but, at the same time, meets the trend for matt surfaces.

The 1mm thick ABS edging matches the Fenix NTA matt metal finish of the same name. The metal finish gives it a particularly high-quality look.

## With real aluminium finish: Alu Gold Brushed

If you prefer your golden edging to shimmer and are looking for a quality solution, you should seek out the ABS edging Alu gold brushed. Just like Alu Oro Cortez, it has a high-quality real aluminium finish. The brushed texture and metallic sheen add a warm hue.

This edging is available from Ostermann in three different thicknesses (0.5mm, 1mm and 2 mm) for a wide scope of possible designs.

## Velvet gold Look: ABS edging Brushed Brass

With its fine Linea structure and its restrained, warm colour, the ABS edging, available in thicknesses of 1mm and 2mm, appears very realistic even without a metal finish.

The velvety gold shade not only matches Egger's decor board of the same name, but also combines excellently with wood decors, especially boards with a slightly reddish base tone.

## ABS edging Sierra Gold

The ABS edging Sierra Gold has a slightly antique look, due to its cloudy colour play. It is available in 2mm thickness and perfectly matches Pfeleiderer's surface of the same name.

## ABS Edging Gold Brushed

The ABS edging Gold Brushed wood pore is slightly darker than the velvet-gold brushed brass variant and significantly lighter and calmer in decor than the Sierra Gold edging. With its warm gold tone, the 1mm thick edging can also be used perfectly as an accentuating edging on plain-coloured boards.

## Europe's largest immediately available range of edgings

Ostermann has all furniture edgings readily available in the company's warehouse. As stock items, they can be ordered by 4pm to be shipped on the same day. In order to maintain this pace even with the growing variety in the product range, the company is continuously investing in state-of-the-art storage and shipping technology.

Want to find out more? Visit [www.ostermann.eu](http://www.ostermann.eu)



DECORATIVE FINISHES

Ostermann demonstrates how to blend in pieces of gold.

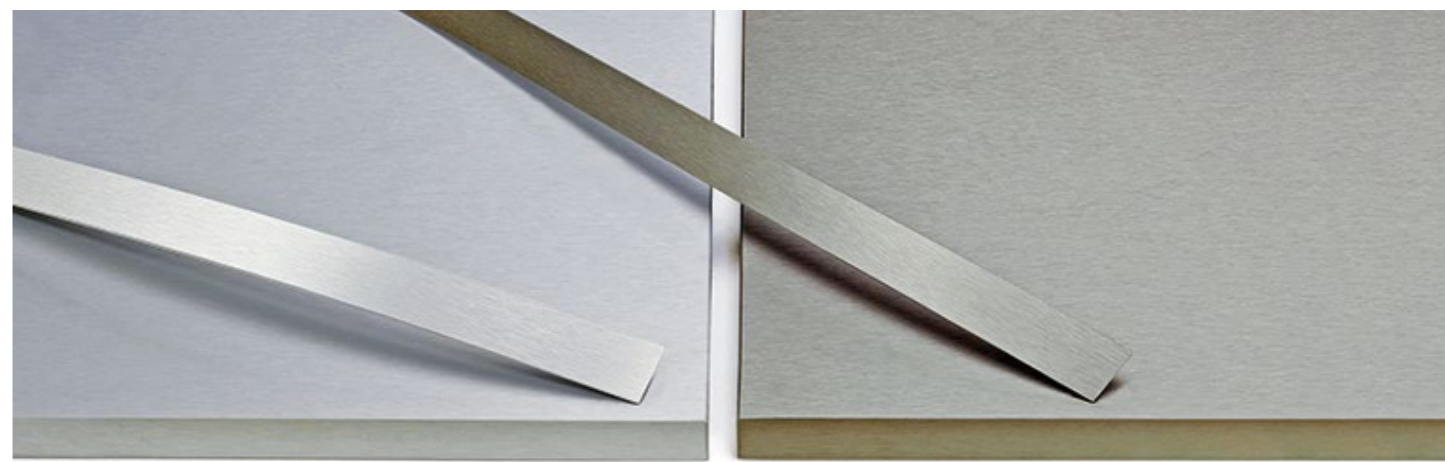

Matt metal: under the names Alu Acciaio Hamilton, Alu Argento Dukat and Alu Oro Cortez, Ostermann provides ABS edgings with a matt real metal plating.

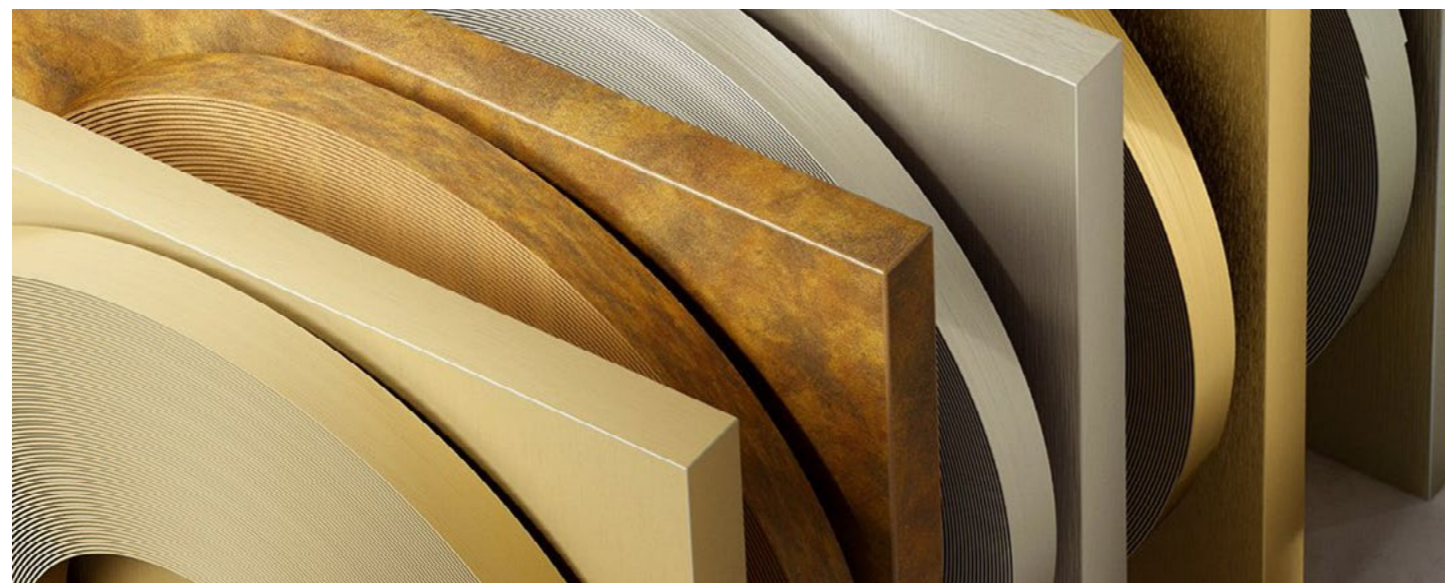

Gold tone diversity: Ostermann supplies the on-trend gold-coloured furniture edgings in many variants. Here you can see (from left to right) the ABS edging Gold brushed wood pore, the ABS edging Sierra Gold Stone Finish, the ABS edging Alu Oro Cortez exclusive matt brushed, the ABS edging Alu gold brushed and the ABS edging Brushed Brass linea structured.

VISIT US AT [WWW.KITCHEN-MAKER.CO.UK](http://WWW.KITCHEN-MAKER.CO.UK) - ONLINE MAGAZINE

VISIT US AT [WWW.KITCHEN-MAKER.CO.UK](http://WWW.KITCHEN-MAKER.CO.UK) - ONLINE MAGAZINE

# LIFE STYLE TRENDS INSPIRED BY NATURE

PANELCO is always at the forefront of committing to new ranges packed with innovation. This impressive launch from Kronospan is no exception, adding over 40 new designs to the already vast range.

This collection displays design impact and originality with the common focus "inspired by Nature". Based around four different life-style trends, each story reveals a personality taste with distinctive style and materials used to create each individual trend.

Kronospan is proud to make environmentally-friendly products, yet still offers a diverse mix of patterns and textures. The creative focus starts with any piece of material that can be transformed into a trend design through the process of digitalisation.

The Nomad story focuses on heavy textures and patterns, weathered oak finishes, warm earth and deep green tones

displaying a natural uncomplicated feel. Meanwhile, the Adaptable trend displays a fun element, with soft pinks balanced by marbles and contemporary natural wood grains.

The Passionate theme is all about opulence and self indulgence. Expect rich dark wood grains with synchronised textures complemented by jewel tones.

Finally, the Optimist provides a positive focus full of playful colour matched with warm tonal wood grains and soft grey hues. Each individual design story has clear origins and styles to really give everyone a vast selection of unique décors and textures. Panelco has committed to stocking all new décors from this new launch.

Want to find out more? Visit [www.panelco.com](http://www.panelco.com)



VISIT US AT [WWW.KITCHEN-MAKER.CO.UK](http://WWW.KITCHEN-MAKER.CO.UK) - ONLINE MAGAZINE



DECORATIVE  
FINISHES

VISIT US AT [WWW.KITCHEN-MAKER.CO.UK](http://WWW.KITCHEN-MAKER.CO.UK) - ONLINE MAGAZINE

# IDS'S GROWING DECORATIVE PANEL PORTFOLIO REFLECTS MARKET DEMAND

SPECIALIST surface materials distributor, IDS is responding to the needs of kitchen furniture manufacturers, designers and fabricators with continued investment across its decorative panel business.

Under new ownership, the company has re-inforced its commitment to its panel division by increasing its warehouse capacity, adding to its team, extending its delivery fleet and, crucially, expanding its vast depth and breadth of decorative panel products in line with market demand.

Ranging from raw boards, MFC, MF MDF, CDF, matching edging tape and more, IDS offers a huge variety of materials from the industry's leading manufacturers including Swiss Krono One World, Fundermax Premium Star, Finsa Superpan and Fibrilux coloured through MR MDF, which are all available from stock.

## New products

New to the range is the Fundermax Premium Star range of super matt and high gloss lacquered decorative panels, combining sophisticated technology with superior visual effects.

Suitable for a wide range of applications, including kitchen fronts, the collection offers a choice of five popular decors, available for tailored nationwide delivery.

Seven further decors and additional thicknesses are also available on extended lead times. The range spans whites, neutrals, greys and black, with the multi-layer lacquer ensuring long-lasting colour.

Meanwhile, the new Fibrilux coloured through MR MDF panels offer a hard, fine and smoothly sanded surface. The moisture-repellent panels can be lacquered, or finished with paper, foil, melamine, veneer, or high pressure laminate.

## Longstanding partnership

IDS also continues to invest in its 30-year partnership with Swiss Krono as the exclusive UK stockist of the One World Collection.

With new racking in place at its Ely and Blackburn branches, IDS has been able to extend the range of ex-stock items available for tailored delivery and any order quantity across the UK. These include 16 trend-led decors in 25mm thickness selected from One World.

The range gives customers the option of low volume orders on design-led decors serviced next day, if required, including the exclusively stocked 134 decor One World range in 18mm thickness.

Swiss Krono panels offers best-in-class environmental credentials which meet the growing requirement for responsible sourcing. The panels feature a 100 per cent virgin wood core and are rated E D2020 as standard for low formaldehyde emissions.

*Pictured Right: IDS has invested in extra racking at its Ely and Blackburn branches to extend the range of ex-stock items available.*

'The new Fundermax Premium Star and Fibrilux ranges complement the existing panel portfolio and bring popular products into the IDS offer,' says business development manager at IDS, Dave Huggins.

'At the same time, we're very proud of our long-standing partnership with Swiss Krono for their genuine Swiss-made products, which offer unrivalled environmental credentials.

'We're committed to bringing new products into the range to meet the changing needs of customers. This only serves to affirm our position as the No 1 option for One World in the UK,' concludes Mr Huggins.

Want to find out more?  
Visit [www.idsurfaces.co.uk](http://www.idsurfaces.co.uk)



DECORATIVE FINISHES



*IDS is now the exclusive UK stockist for Fundermax Premium Star decorative panel. Pictured is the City Grey décor in a super matt finish.*



# NEW EUROPEAN KITCHEN DOOR COLLECTION FROM HPP

A KITCHEN door collection currently being imported from Europe has been extended by a new range manufactured in-house by Hill's Panel Products (HPP) - the Oldham-based board, doors and fittings distributors and suppliers.

The doors are part of HPP's Avanti off-the-shelf collection. Named Juno, they comprise a range of so-called "Skinny Shakers" - a modern twist on the traditional Shaker-style door, but with thinner stiles - that will sit alongside the existing Avanti range.

'We've had Brexit, the pandemic and now the state of the economy, which makes the exchange rate between sterling and the Euro unfavourable. Add in logistics, the cost of fuel, lead times and the availability of materials - bringing in doors from the Continent ticks a lot of the wrong boxes,' says HPP's marketing and business development director, Dan Mounsey.

'Taking into the account those pressures; we've decided to manufacture in-house,' adds Mr Mounsey.

Based on HPP's Mercia door in the Aspire made-to-measure range, Juno features a 60mm slim profile and is available in a choice of four super matt décors; dust grey, black, indigo blue and highland green - all on-trend colours and all available for next-day delivery nationwide.

Each range is available in approximately 60 SKUs, including doors, drawer fronts, end panels, cornices, plinths and filler panels in a wide variety of sizes and all available to order online.

'As we're manufacturing in-house, there is also a made-to-measure option, which will make this range unique. So customers could order 90 per cent of what they need off the shelf and then have the rest made-to-measure. Overall, it creates great versatility,' declares Mr Mounsey.

As with the other doors in the Avanti range, Juno comes undrilled as standard, but a bespoke hinge hole drilling service is available with a one-day lead time.

HPP first introduced its Avanti stock door collection to great customer acclaim in 2011 and has seen it evolve over the years to keep pace with changing trends and fashions.

The current range consists of:

- Alto - another modern interpretation of the classic Shaker-style door.
- Legno - which comes with an integrated J-Pull handle and horizontal grained door style.
- Opus - available in matt white, or a range of high gloss finishes with an integrated J-Pull handle.
- Quadro - a classic Shaker-style door with grained painted effect décors.

'This will continue the growth for the Avanti range, which has been a great success since we launched it in 2011. It makes a significant contribution to the business and always has done,' says HPP sales manager, Chris Essex.

'Juno is going to do really well, because it is very much on trend with the demand for matt colours and the slim shaker-style.

'In a stock door range, you want to have something for everyone, but that can't always be so, which is why we have the made-to-measure facility, but this new door is taking the range where it needs to go to keep the Avanti success on track,' concludes Mr Essex.

Want to find out more? Visit [www.hpponline.co.uk](http://www.hpponline.co.uk)



Juno in Super Matt Indigo Blue.

VISIT US AT [WWW.KITCHEN-MAKER.CO.UK](http://WWW.KITCHEN-MAKER.CO.UK) - ONLINE MAGAZINE



Juno in Super Matt Dust Grey.



Juno in Super Matt Highland Green.

VISIT US AT [WWW.KITCHEN-MAKER.CO.UK](http://WWW.KITCHEN-MAKER.CO.UK) - ONLINE MAGAZINE

# MAKING THE MOST OF EVERY INCH OF SPACE IN YOUR KITCHEN

Blum shows us how to increase storage capacity with its kitchen drawer boxes and inserts.

WHEN it comes to carefully planned storage, kitchens are where it matters most. With everything from crockery, cookware and cutlery to utensils, gadgets, food and all those bits and bobs, such as scissors, batteries, chargers and pens, there's a lot to fit in.

That's where kitchen drawers can help. While cupboards and shelves are commonly used to create storage both above and below the work surface, it's the drawers that offer extra space with the option to organise thanks to dedicated fittings and inserts.

As the leading name in precision engineered fittings, drawer runners, boxes, inserts, pull-outs and lift systems, Blum knows all about making the most of every inch.

'Drawers are definitely the way to go with kitchen storage,' says Blum UK's expert for ergonomics, Amanda Hughes.

'They may be more of an investment piece than cupboards and shelves, but they fit more in. This allows users to do away with wall units altogether if they wish – especially if they want to make a small kitchen feel larger – without worrying about the cost, as the total price tends to be about the same. Drawers provide more usable storage space and they are much more future-proof, as they are easier to access for all ages and abilities,' she adds.

## **Blum Legrabox and Tandembox**

There are so many advantages to planning a kitchen with drawers rather than cupboards and shelves. Doing away with wall units altogether prevents the space from feeling cramped and closed in.

It's a great way of making a small kitchen instantly feel lighter, brighter and larger. In addition, there's the bonus of being able to find everything quicker and easier.

No more hunting around the back of dark cupboards for that elusive colander. With drawers, nothing is lost at the back and everything is instantly accessible, saving both time and energy.

Drawers also fit a lot more in and the bigger, the better. Extra wide 1,200mm drawers for instance provide 15 per cent more storage space than two standard 600mm drawers. Weight is also nothing to worry about, especially with Blum drawer boxes.

Depending on the width and runner system, Legrabox can hold 70kg and Tandembox, 60kg. Use them all around the kitchen, including the island.

## **Blum Ambia-Line for Legrabox**

For anyone looking to be more organised in their kitchen, Blum's AMBIA-LINE inner dividing box system for Legrabox is a quick and efficient way of keeping loose bits and pieces in their place.

Style-wise it's sleek and streamlined with an on-trend black finish and slim frames that can be slotted wherever needed. Its fuss-free design allows users to hold the frames in place with magnets while anti-slip feet keep contents securely in place.

The "before" and "after" images on page 20 show how easy it is to clear the clutter and ensure the kitchen drawer is a joy rather than a dread.

Drawers can also be used to make the under-sink space much more usable, too. Perfect for recycling bins, cleaning products, bin bags, dustpan and brush and all the paraphernalia that kitchens need to keep them clean and working efficiently.

Want to find out more? Visit [www.blum.com](http://www.blum.com)



Blum drawers (left) versus standard cabinets and wall units (right).

VISIT US AT [WWW.KITCHEN-MAKER.CO.UK](http://WWW.KITCHEN-MAKER.CO.UK) - ONLINE MAGAZINE



Blum 1,200mm sink unit.

VISIT US AT [WWW.KITCHEN-MAKER.CO.UK](http://WWW.KITCHEN-MAKER.CO.UK) - ONLINE MAGAZINE



Blum Ambia-Line before (above) and after (below).



Island unit with two 1,400mm Legrabox units.



# SAVE TIME WITH TITUS T-TYPE HINGES

FASTFIX hinge cup and pie-cut corner hinges are the latest additions to the popular and successful T-type hinge range from cabinet hardware expert, Titus.

The new-generation T-type hinges reliably deliver the soft closing action preferred by end users and require only a shallow hinge cup, which makes them suitable for use with door thicknesses ranging from 15mm to 26mm – and they have passed FIRA tests for BS 6222-2-2009, Test Level H.

FastFix hinge cup features pre-mounted 8mm diameter expanding dowels that enable precise tool-free insertion and hold the hinge cup accurately in place until the dowels are tightened, making hinge attachment quick and easy. Triple-start screws provide additional time savings.

T-type pie-cut corner hinge offers full door opening to 170 deg, giving easy access to cabinet interiors. In addition, when both doors are opened, the first is locked at 25 deg to the second, so that both move away from the user and are prevented from hitting adjacent cabinets. The pie-cut hinge uses a standard 35mm diameter drilling pattern and needs no edge drilling.

The T-type hinges feature the renowned Titus Confident Close, the consumer-preferred reliable and consistent soft-close damping characterised by late-start deceleration and quiet landing in the last stage of closing as the door leans against the cabinet side.

The proprietary Titus multi-purpose integrated damping technology is positioned transversal in the hinge cup, ensuring life-long damping with no bounce-back and superior performance.

In addition, the hinges are exceptionally tolerant of misalignment and drilling variations. Their unique three-way tool-less snap-on mounting plate, which offers intuitive hinge-to-plate

mounting in three directions, greatly simplifies door installation, especially with tall doors that need four, or even five hinges.

The unique design of the mounting plate re-inforces stability and rigidity while maintaining smooth hinge operation.

The hinges feature the renowned Titus damper Inside technology, which ensures reliable and consistent life-long damping without re-bounce. The dampers are single-direction hydraulic types that are fully sealed to eliminate the possibility of oil leakage. The damping is easy to adjust, which maintains consistent performance on doors with a wide range of different dimensions and weights.

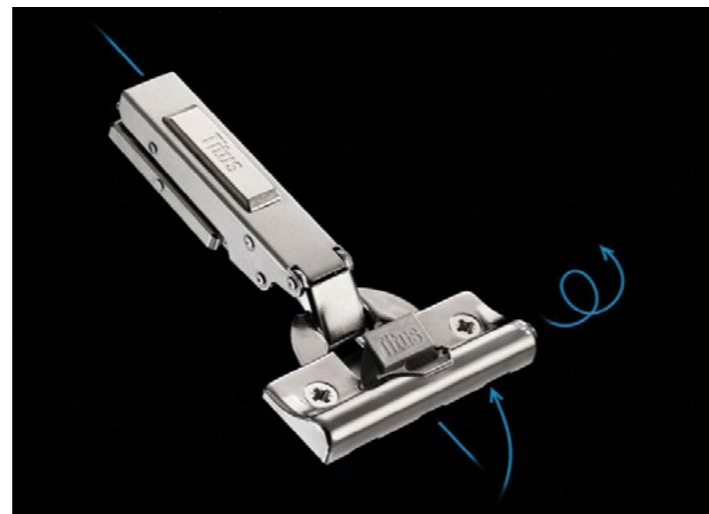

Want to find out more? Visit [www.titusplus.com](http://www.titusplus.com)

VISIT US AT [WWW.KITCHEN-MAKER.CO.UK](http://WWW.KITCHEN-MAKER.CO.UK) - ONLINE MAGAZINE



- 16 mm
- 17 mm
- 18 mm
- 19 mm

## Tandem 19mm for thick drawer sides

Specially designed and upgraded for wooden drawers with a thickness of 17 to 19 mm to allow for even more design opportunities. Available now at Isaac Lord.

[info@isaaclord.co.uk](mailto:info@isaaclord.co.uk) | [www.isaacclord.co.uk](http://www.isaacclord.co.uk)  
01494 835200

# TITUS T-TYPE HINGES COMBINE EASE OF USE WITH VERSATILITY

CABINET hardware expert, Titus has launched its versatile new-generation T-type hinges that reliably deliver the soft closing action preferred by end users.

The new hinges require only a shallow hinge cup, which makes them suitable for use with door thicknesses ranging from 15mm to 26 mm and they have passed FIRA tests for BS 6222-2-2009, Test Level H.

The T-type hinges feature the renowned Titus "Confident Close" - the consumer-preferred reliable and consistent soft-close damping characterised by late-start deceleration and quiet landing in the last stage of closing as the door leans against the cabinet side.

The proprietary Titus multi-purpose integrated damping technology is positioned transversal in the hinge cup, ensuring life-long damping with no bounce-back and superior performance.

In addition, the hinges are exceptionally tolerant of mis-alignment and drilling variations. Their unique three-way, tool-less snap-on mounting plate, which offers intuitive hinge-to-plate

mounting in three directions, greatly simplifies door installation, especially with tall doors that need four, or even five hinges. The unique design of the mounting plate reinforces stability and rigidity while maintaining smooth hinge operation.

The hinges feature the renowned "Titus Damper Inside" technology, which ensures reliable and consistent life-long damping without rebound.

The dampers are single-direction hydraulic types that are fully sealed to eliminate the possibility of oil leakage.

The damping is easy to adjust, which maintains consistent performance on doors with a wide range of different dimensions and weights.

Titus T-type hinges can be supplied with cross-mounting plates, or with linear mounting plates that simplify both hinge alignment and hinge-to-plate attachment. The new hinges are fully compatible with Glissando TL and the TitusTUS Push Latch.

Want to find out more? Visit [www.titusplus.com](http://www.titusplus.com)



VISIT US AT [WWW.KITCHEN-MAKER.CO.UK](http://WWW.KITCHEN-MAKER.CO.UK) - ONLINE MAGAZINE



VISIT US AT [WWW.KITCHEN-MAKER.CO.UK](http://WWW.KITCHEN-MAKER.CO.UK) - ONLINE MAGAZINE

# WREN KITCHENS HAS PLANS TO CREATE UP TO 1200 NEW JOBS

WREN Kitchens is planning to create up to 1200 new jobs at its Barton-upon-Humber headquarters, as it prepares to invest over £120m in its fourth manufacturing facility in the Humber region.

The UK's No 1 kitchen retailer is submitting a planning application for a new 910,000ft<sup>2</sup> facility to be built behind the existing north Lincolnshire factory on part of its 180-acre site.

From opening its first showroom 10 years ago, Wren has grown to become the UK's largest kitchen retailer with 78 showrooms nationwide. The company requires this new

facility to keep-up with its future expansion plans in the Humber area.

Wren Kitchens currently employs more than 1500 people at its headquarters in Barton, with another 1000 employed at its sites in Scunthorpe, Howden and in Hull. If the planning application is approved, Wren is confident that up to 1200 new jobs will be created when the factory is fully operational.

'This project will be the largest single investment in Wren's history and having considered different locations both across the UK and abroad, we believe that developing the existing site



in Barton-upon-Humber provides us with the best possible solution for our continued growth,' says managing director, Mark Pullan.

'The new factory demonstrates our commitment to manufacturing in the UK and particularly the Humber Region. We believe that continual re-investment in our business is essential to maintaining our current growth rate and subject to receiving planning approval, the project will be funded internally,' adds Mr Pullan.

Aside from the 1200 new manufacturing roles, Wren will also be creating new positions in IT development, engineering, customer service and product development to keep pace with growing customer demand.

Wren is celebrating its tenth anniversary and earlier this year was named the UK's best place to work by leading jobs website, Indeed.co.uk.

'It's a fantastic vote of confidence for the business and for North Lincolnshire that Wren Kitchens is looking to expand its operations in Barton,' says leader of North Lincolnshire Council, Cllr, Rob Waltham.

'The move could see more highly skilled jobs brought to our area and such large private investments often prove to be a catalyst for further investments in the surrounding areas,' says Cllr Waltham.

Want to find out more? Visit [www.wrenkitchens.com](http://www.wrenkitchens.com)



VISIT US AT [WWW.KITCHEN-MAKER.CO.UK](http://WWW.KITCHEN-MAKER.CO.UK) - ONLINE MAGAZINE

VISIT US AT [WWW.KITCHEN-MAKER.CO.UK](http://WWW.KITCHEN-MAKER.CO.UK) - ONLINE MAGAZINE

# The Woodwork Dust Control Co Ltd

Leaders in Dust Control Technology

A Complete Wood Waste Extraction Service to all Timber Industries

- ★ Design, Manufacture, Installation
- ★ Large hopper filters, fans, cyclones
- ★ Small bag filters, rigid ductwork, flexible hose
- ★ LEV COSHH testing, assessment, service
- ★ EWI-THERM Wood burning stoves
- ★ Fast nationwide service



Contact us for our FREE product catalogue:

Tel: 01844 238833 Fax: 01844 238899

Email: [enquiries@woodworkdustcontrol.co.uk](mailto:enquiries@woodworkdustcontrol.co.uk)

Web: [www.woodworkdustcontrol.co.uk](http://www.woodworkdustcontrol.co.uk)

